

ESSENTIALS SERIES DESKTOP MONOCHROME PRINTER

Desktop Printer Built with the Office in Mind

The DX-B352P Essentials Series Monochrome Printer delivers an output speed of up to 35 pages per minute (ppm) with advanced durability to ensure years of reliable and carefree operation. Offering both wired and wireless network connectivity, along with a compact footprint, this printer can adapt to any busy office environment. The DX-B352P even makes changing supplies easy. Utilizing a single cartridge system, office users can quickly change all key components by simply replacing one cartridge.

Key Features

- **Versatile** – A compact design combined with wireless networking capability makes the DX-B352P the ideal printer for offices with limited space.
- **Productive** – Delivers crisp output every time for all your document formats via standard PCL®6 and PostScript®3™ printing protocols.
- **Quick Setup** – Using a one-step installation process and an easy-to-use keypad, users can quickly control the print language, power settings, network configurations and security options.



DX-B352P shown with optional 550-sheet paper drawer.



Compact Design easily fits into small office spaces



Easy-to-use 2-line LCD operation panel



Print on envelopes and special media via bypass tray

Print capabilities to help your business gain a competitive advantage

- Productive printing speeds up to 35 ppm
- Automatic two-sided function for duplex printing
- Standard network and wireless network connectivity
- Compact design easily fits into small office spaces
- 1,200 x 1,200 dpi printing delivers clear, crisp images and text page after page
- Standard PLC 6 and PostScript 3 printing
- Triple your printing with optional paper drawer, 1,410-sheet maximum paper capacity
- Auto-sleep mode creates less noise pollution and gives peace of mind
- Standard and optional paper drawer hold up to legal size paper
- Easily change all supplies using a single cartridge system

DX-B352P SPECIFICATIONS

Main Specifications

Type	Desktop monochrome printer
Display	2-line LCD Panel
Print System	Dry electrostatic transfer/Mono component/OPC drum/roller fusing/white LSU exposure
Output Size	Min. 5½" x 8½", Max. 8½" x 14"
Print Speed	35 ppm
First Print Time (in seconds)*	8.5 seconds
Warm Up Time	20 seconds
Paper Capacity	Standard: 310 Sheets, Maximum 1,410 Sheets
Paper Feed System	Standard: (1) 250-sheet paper drawer (letter/statement/legal/executive size) system and 60-sheet bypass tray (letter/statement/legal/executive/envelope size). Optional: (1) 550-sheet paper drawer (letter/statement/legal/executive size).
Paper Weights and Types	Paper drawers: 16-28 lb. bond. Other paper types include thin, plain, pre-printed, recycled, pre-punched, letterhead and color paper. Bypass tray: 16-19 lb. bond (thin paper), 16-28 lb. bond (plain paper), 28 lb. bond -74 lb. cover (heavy paper), Monarch/Com-10 envelope. Also, label paper, gloss paper, pre-printed paper, recycled, pre-punched, letterhead, color paper and OHP film.
Duplexing	Standard automatic duplex printing
CPU	600 MHz
Interface	RJ-45 Ethernet (10Base-T, 100Base-TX), Wireless IEEE802.11 n/g/b), support WPS, USB 2.0 (1 device port, rear)
Printer Memory	Standard: 256 MB
Firmware Management	Firmware can be updated by USB or wired network connection.
Device Setup	Web-based management/admin level login
Service/Functions	Remote access to toner level

Design and specifications subject to change without notice.

Main Specifications (continued)

Accessibility Features	Beep sound features on key entry, adjustment of key touch sound, screen timeout disable
Environmental Standards	ENERGY STAR® Program Ver. 3.0
Power	AC 110 VAC, 60HZ, 8 A
Power Consumption	0.5 kW or less
Weight	Approx. 20.7 lbs.
Dimensions	Approx. 14.6" (w) x 14.6" (d) x 11.3" (h)
PDL	PCL5e, PCL6/XL, PostScript 3 compatible, PDF
Resolution	Max. 1,200 x 1,200 dpi
Print Drivers	Windows® Server 2003, Server 2008, Server 2012, Windows XP, Windows Vista, Windows 7, Windows 8, Windows 8.1, Windows 10 x64, MAC OS (including 10.7 to 10.13)
Features	Wireless connectivity, duplex printing, driver delivery functions, toner save mode, power save mode, electronic sorting, N-up printing, image rotation, watermark
Resident Fonts	PCL5e, PCL6/XL, PS3, PDF
Network Interface	10/100/1,000BaseTX, Ethernet, IEEE 802.11b/g/n, USB 2.0 (High Speed)
Operating Systems	Windows Server 2003, 2008 & 2012, Windows XP, Vista, 7, 8, 8.1, 10, Mac OS 10.7-10.13
Network Protocols	Ipv4, DHCP, DNS, RAW (Port9100), LPD / LPR, SNMP (v1), SMTP, HTTP/HTTPS (v1.1)
Printing Protocols	Raw TCP and LPD (port 9100), AirPrint, Wireless IPP (default)
Network Security	SSL/ TLS

Optional Equipment

DX-B35TD	Toner and Drum
----------	----------------

* May vary depending on product configuration, machine settings and operating and/or environmental conditions.

Product Configuration

DX-B352P
(standard drawer)
310-sheet maximum

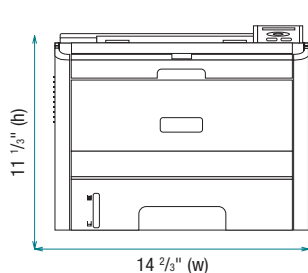

DX-B352P + DX-CS11
(1 additional drawer)
860-sheet maximum

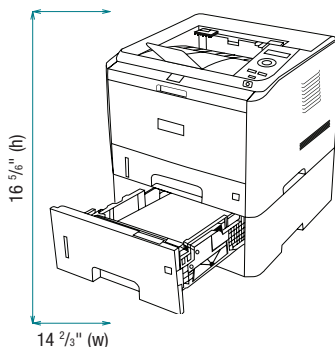

DX-B352P + DX-CS11
(2 additional drawer)
1,410-sheet maximum

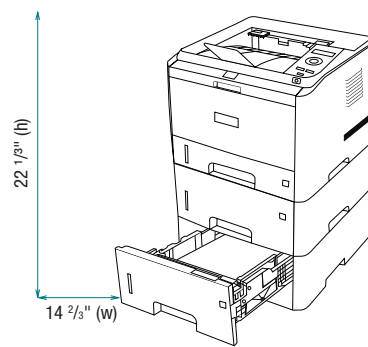

SHARP ELECTRONICS CORPORATION
100 Paragon Drive, Montvale, NJ 07645
1-800-BE-SHARP • www.sharppusa.com

Sharp and My Sharp and all related trademarks are trademarks or registered trademarks of Sharp Corporation and/or its affiliated companies. Windows and Windows Server are registered trademarks of Microsoft Corporation. PCL is a registered trademark of Hewlett Packard Company. PostScript is a registered trademark of Adobe Systems Inc. MacOS and Airprint are registered trademarks of Apple Inc. All other trademarks are the property of their respective owners.